

RAiO

RA8825

128x33 Dot Matrix

LCD Driver

Specification

Version 1.1

March 2, 2006

RAiO Technology Inc.

©Copyright RAiO Technology Inc. 2005, 2006

1. General Description

The RA8825 is a Dot-Matrix LCD Driver. The embedded 528Byte display RAM supports up to 128x33 dots LCD panel. The RA8825 also provides a scrolling buffer memory for scrolling functions. It supports up, down, left and right scrolling features, and all of the scrolling functions are execute by hardware.

The RA8825 integrates many powerful hardware that including Contrast adjustment, 4x5 Key-Scan, eight General Purpose I/O and EL Backlight signals for EL driver. The RA8825 is a high integration chip of LCD Controller. It reduce a lot of time for system develop, and save much cost for hardware system that due to it provides many features for related LCD display application.

2. Feature

- Support 8080/6800 8/4-bit Parallel Interface and 3-wire/4-wire Serial Interface
- Support Maximum 128Seg x 33Com LCD Panel.
- Built-in 528 Bytes Display RAM and 354Byte Scrolling Buffer
- Built-in 2X~3X(Voltage Booster), Voltage Regulator, Voltage Follower
- Support 1/33 Duty, 1/6~1/4 Bias Panel
- Eight General Purpose I/O
- Built-in 4x5 Key Scan Circuit
- Support Horizontal/Vertical Scrolling Functions
- Provide Signals for EL Driver
- Provide 32-Steps Contrast Adjust
- Build-in RC Oscillator
- Voltage Operation : 2.6~3.6V
- Package : Gold Bump Die

3. System Block Diagram

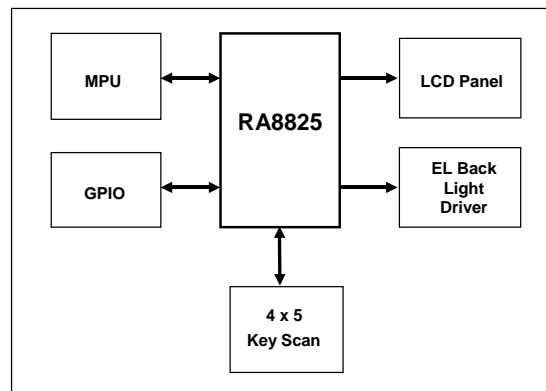

4. Pad and Package

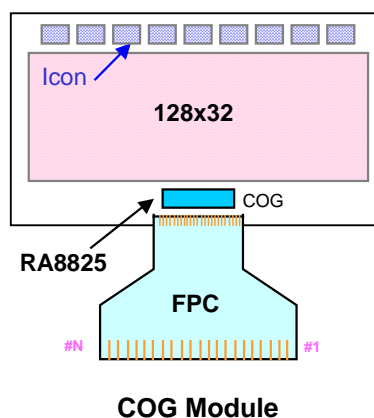

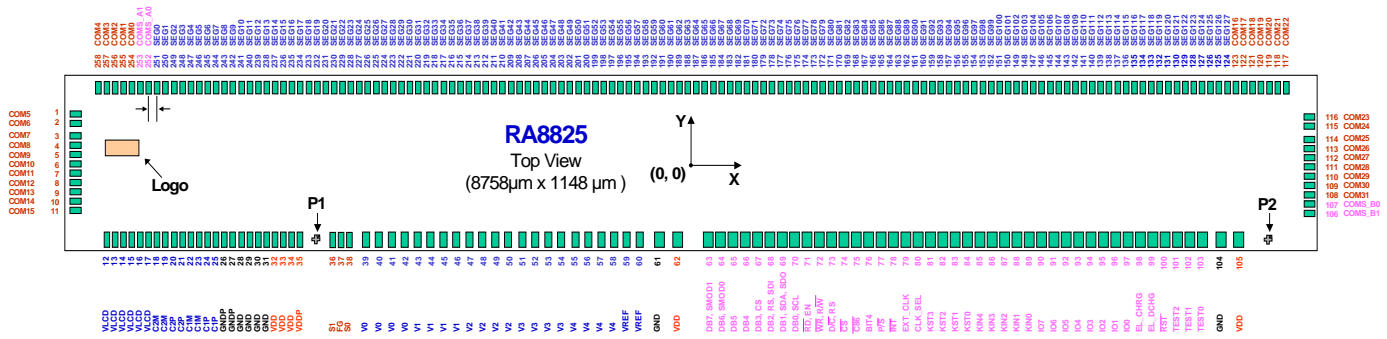

5. Block Diagram

The RA8825 consists of Display RAM, Command Registers, LCD Controller, LCD Driver, Voltage Booster, Voltage Regulator, MPU Interface and Key-Scan circuit.

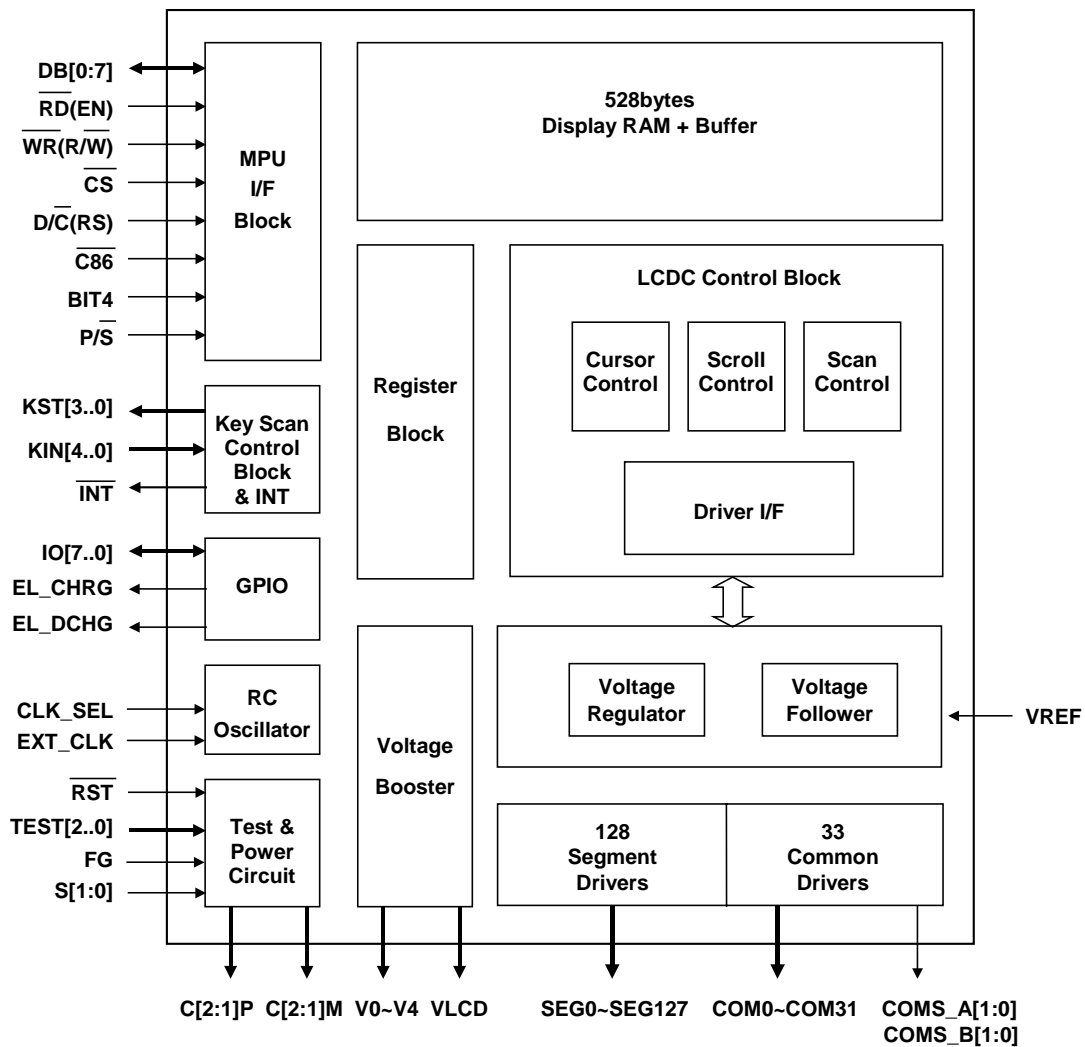

6. Pin Definition

5-1 MPU Interface

Pin Name	I/O	Description
<p>DB[7..0]</p> <p>DB0: SCK DB1: SDA/SDO DB2: RS/SDI DB3: \overline{CS} DB[7:6]: SMOD</p>	I/O	<p>Data Bus When the MPU use parallel mode and 8-bit then all of the DB[7:0] are valid. When use 4-bit then only DB[4:0] are valid, and DB[7:4] have to keep floating.</p> <p>When P/\overline{S} is "0", then the interface between MPU and RA8825 is Serial Mode. The pins DB[7:6](SMOD[1:0]) are used to select which serial mode:</p> <p>SMOD : Serial Mode -----</p> <p>0 X : 3-Wire, SCK, SDA, are used. 1 0 : 4-Wire, SCK, SDA, RS, are used. 1 1 : 4-Wire, SCK, SDO, SDI, \overline{CS} are used.</p> <p>In serial mode, all of the related signals are defined by DB[3:0]: SCK(DB0) : Serial Clock. SDA(DB1) : Bi-direction Mode Serial Data. SDO(DB1) : Data Out. RS(DB2) : Memory/Register Cycle Select. SDI(DB2) : Serial Data In. \overline{CS}(DB3) : Chip Select, active low. The unused pin must keep NC for serial mode.</p>
EN	I	<p>Read Control or Enable When use 8080 series interface, is the read signal and active low. When use 6800 series interface, EN is the Enable signal and active high. Connect this pin to VDD for serial mode.</p>
R/	I	<p>Write Control or Read-Write Control When use 8080 series interface, is the write signal and active low. When use 6800 series interface, this pin is R/ , active high for read cycle and active low for write cycle. Connect this pin to VDD for serial mode.</p>
D/ RS	I	<p>Data/Command Select or Register Select) When use 8080 series interface, this is Data or Command signal. When D/\overline{C} is "0", means Register Cycle(or Command Cycle). When D/\overline{C} is "1", means Data Access Cycle(Data Cycle). When use 6800 series interface, this is the RS signal. When RS is "0", means Register Cycle and "1" means Data Access Cycle. Connect this pin to VDD for serial mode.</p>
\overline{CS}	I	<p>Chip Select This is a chip enable for RA8825. Connect this pin to VDD for serial mode.</p>
	O	<p>Interrupt Signal This is an interrupt output for MPU. Active low ◦</p>

	I	MPU Select $\overline{C86} = 0 \rightarrow$ The MPU interface is 8080 series. $\overline{C86} = 1 \rightarrow$ The MPU interface is 6800 series(Default). Connect this pin to VDD for serial mode.
BIT4	I	Data Bit Select BIT4 = 0 \rightarrow The parallel mode is use 8-bit data bus. BIT4 = 1 \rightarrow The parallel mode is use 4-bit data bus(Default). Connect this pin to VDD for serial mode.
P/ \overline{S}	I	Parallel/Serial Select $P/\overline{S} = 0 \rightarrow$ The MPU interface is serial mode(Default). See the setting of DB[7:6]. $P/\overline{S} = 1 \rightarrow$ The MPU interface is parallel mode.

5-2 LCD Panel Interface

Pin Name	I/O	Description
SEG0 ~ SEG127	O	Segment Signals for Panel
COM0 ~ COM31	O	Common Signals for Panel
COMS_A[1:0] COMS_B[1:0]	O	Icon Common Signals for Panel

5-3 Clock and Power

Pin Name	I/O	Description
V0~V4	O	Voltage Source of LCD Driver The relationship of the power is $V_{LCD} > V0 \geq V1 \geq V2 \geq V3 \geq V4 \geq VSS$. These pins have to add external 0.1uF~1uF capacitor to GND.
C1P, C1M	I	Capacitor Input These are used to connect a capacitor for internal Booster.
C2P, C2M	I	Capacitor Input These are used to connect a capacitor for internal Booster.
VLCD	O	Booster Output
VREF	I	Reference Voltage Input This is the reference voltage input when use an external regulator. Normally keep this pin floating, if connect this signal to FPC then have to add a 0.1uF capacitor to GND.
CLK_SEL	I	Clock Select This pin is used to select the clock source. When CLK_SEL "1", the clock is generated by internal RC oscillator. When CLK_SEL is "0", the system clock is drive by external pin - EXT_CLK.
EXT_CLK	I	External Clock When CLK_SEL is "0", this pin is the external clock input. When CLK_SEL is "1", this pin do not used and has to connect VDD or GND.

VDD VDDP	P	VDD Power
GND GNDP	P	Ground

5-4 Misc.

Pin Name	I/O	Description
KST[3..0]	O	Key Strobe Output
KIN[4..0]	I	Key Data Input Connect these pins to VDD for unused.
IO[7..0]	I/O	General Purpose I/O
EL_CHRG	O	EL Charge Signal
EL_DCHG	O	EL Discharge Signal
$\overline{\text{RST}}$	I	Reset This is Reset signal and active low,
TEST[2..0]	I	Test Pins These pins must contact to GND for normal mode.
S[1:0], FG	I	Test Pins These pins must keep NC for normal mode.